

Part. S0340

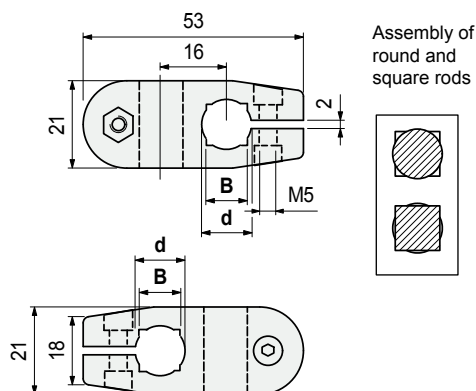

■ Cross clamp



Tightening bolt material	Rod dia. d mm	Square rod B mm	Code	Weight kg
Austenitic stainless steel	10	8	68373	0,02
	12	10	68385	
	14	12	67375	
Zinc plated steel	12	10	627041	

- Material: clamp in reinforced polyamide PA FV (black).
- Max. recommended tightening torque: 0,5 Kgm.
- Packaging: 24 pieces.

Part. S0174



■ Cross clamp

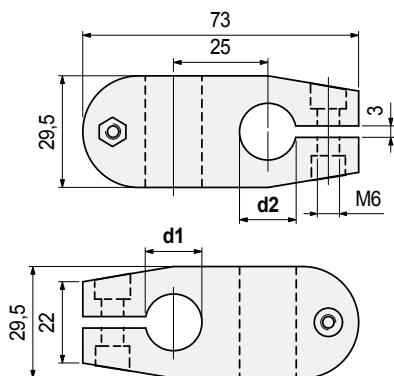

Material	Rod dia. d1 mm	Rod dia. d2 mm	Code	Weight kg
Reinforced polyamide PA FV (black)	14	14	S017457941	0,07
	16	16	S017453781	

- Material: tightening bolt in austenitic stainless steel.
- Max recommended tightening torque: 1 Kgm (Part. S0174); 1,5 Kgm.
- Packaging: 24 pieces.

• Deflection of Part. S0340

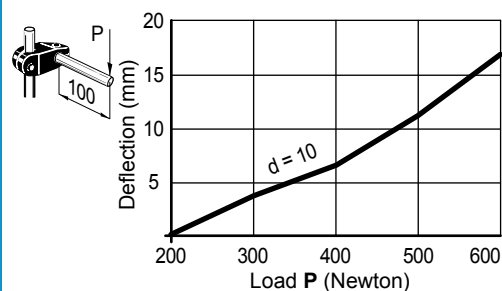

• Technical data Part. S0340

- sliding load: 1200 N
- rotation load: 5 N/m
- Tests performed at tightening torque: 0,5 Kgm

• Deflection of Part. S0174 - S0174R

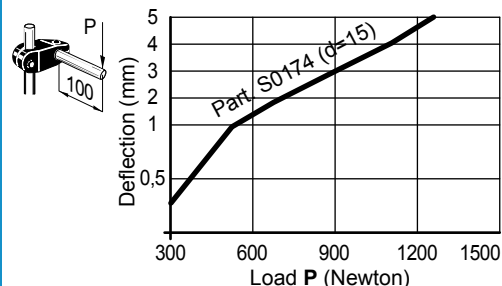

• Technical data Part. S0174

- sliding load: 2500 N (width d = 14 - 15 - 16)
2800 N (width d = 18)
- rotation load: 13 N/m
- Tests performed at tightening torque: 1 Kgm

• Assembly of Part. S0174 with ratchet handle

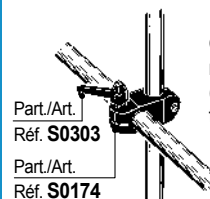

Part./Art.
Réf. S0303

Part./Art.
Réf. S0174

Can be applied with the ratchet handle Part. S0303 (code 60922), instead of the standard hardware.

Part. S0339



T-clamp

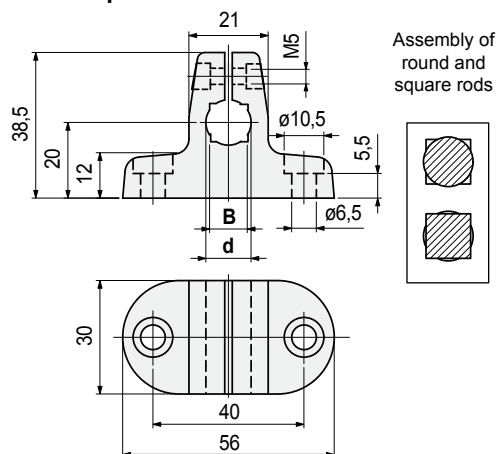

Tightening bolt material	Rod dia. d mm	Square rod B mm	Code	Weight kg
Austenitic stainless steel	10	8	68363	0,03
	12	10	68375	
	14	12	67365	
Zinc plated steel	12	10	627011	

- Material: clamp in reinforced polyamide PA FV (black).
- Max. recommended tightening torque: 0,5 Kgm.
- Packaging: 24 pieces.

Deflection of Part. S0339

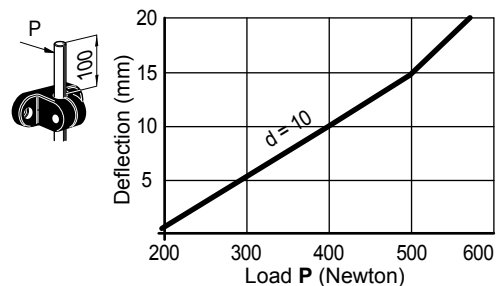

Technical data Part. S0339

- sliding load: 650 N
- rotation load: 5 N/m
- Tests performed at tightening torque: 0,5 Kgm

Assembly of Part. S0339

Can be used in combination with Part. S0340

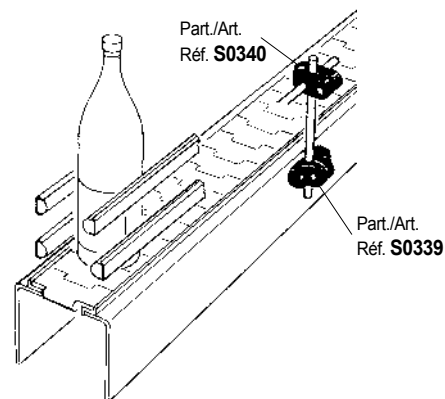

• Characteristics of Part. S0786

Are indicated for end-line applications, to support centre guide or dividers, to separate and align containers before packing area.

• Use of Part. S0786 (for square and round tubes)

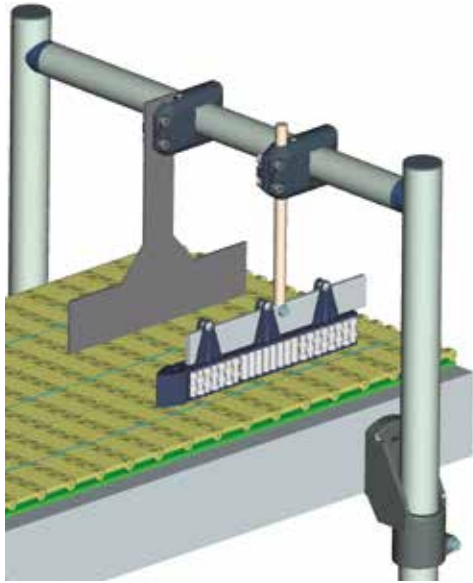
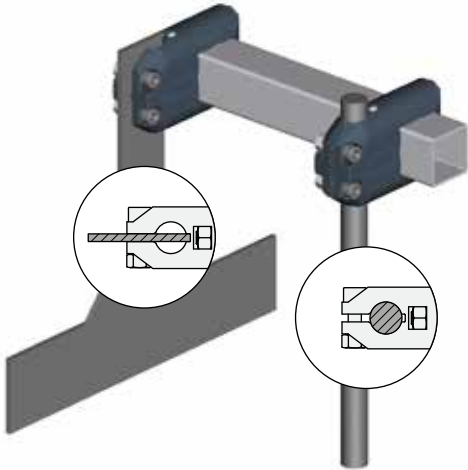

• Use of Part. S0786 (for square and round tubes)



Ratchet handle
spare part code
S0303622433

■ Cross clamp

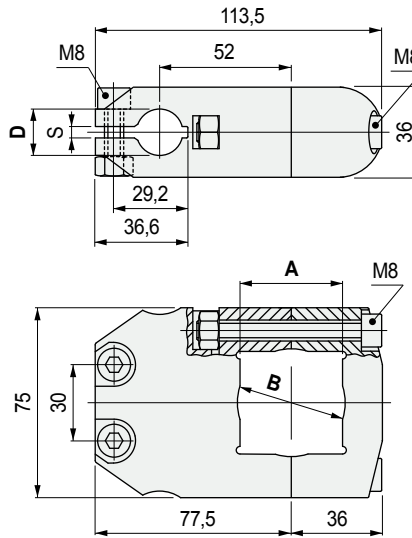

Square tube A mm	Round tube B mm	Round rod D mm	Plate S mm	Code	Weight kg
40	42,4	20	4	621783	0,27

- Material: clamp in reinforced polyamide PA FV (black), tightening screws in austenitic stainless steel, nuts in nickel plated brass.
- Max recommended tightening torque: 2 Kgm.
- Packaging: 8 pieces.

■ Cross clamp

With knob and ratchet handles

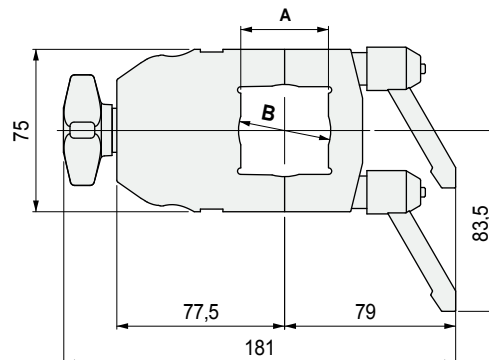

Square tube A mm	Round tube B mm	Rod dia. C mm	Rod dia. d1 mm	Code	Weight kg
40	42,4	52	20	622423	0,30

- Material: clamp in reinforced polyamide PA FV (black), tightening screws in austenitic stainless steel.
- Ratchet handle: handle in reinforced polyamide in PA FV (black), spindle in zinc plated steel.
- Max recommended tightening torque: 2 Kgm.
- Packaging: 8 pieces.

Part. S0786



Part. S0786

